

Online Dissolved Oxygen Sensor

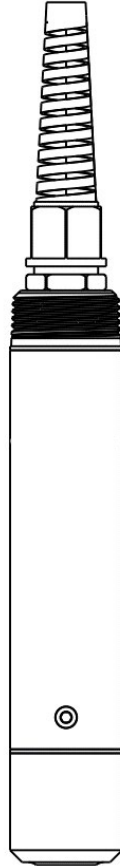

S-DO011

User Manual

USER NOTICE

- ⦿ Please read this instruction manual carefully before use and keep it for reference.
- ⦿ Please follow the operating procedures and precautions in this manual.
- ⦿ When you receive the instrument, please open the package carefully and check whether the instrument and accessories are damaged during transportation. If damage is found, please notify the manufacturer and dealer immediately and keep the packaging for return processing.
- ⦿ When the instrument fails, please do not repair it by yourself, please contact the manufacturer's maintenance department directly.

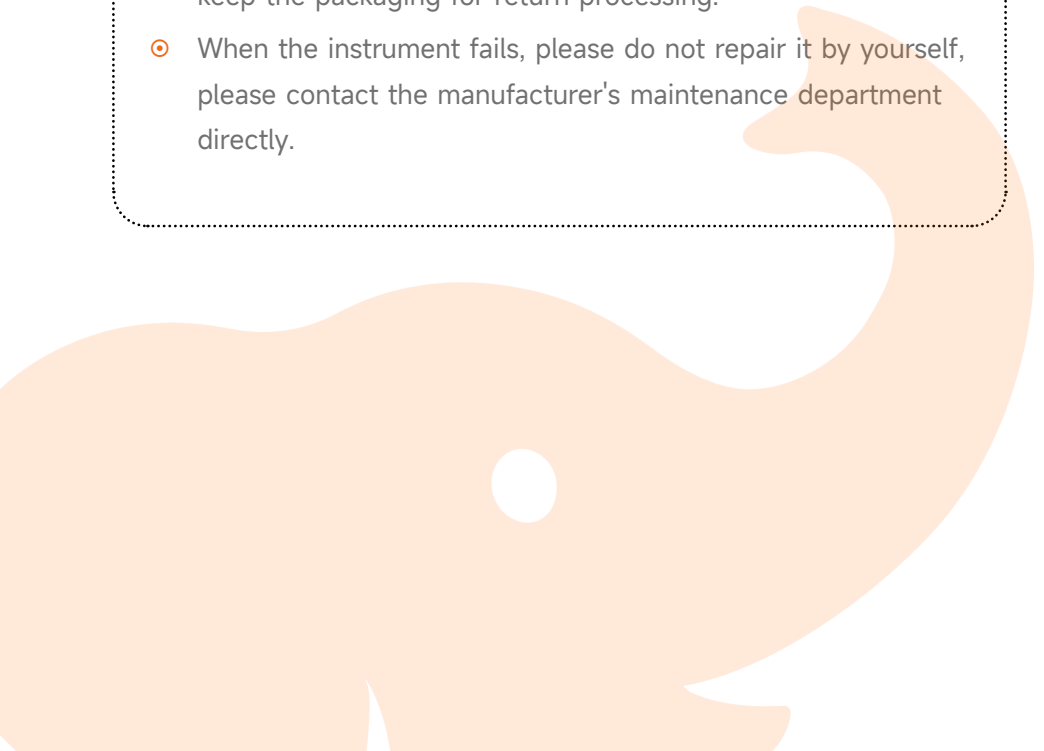

CONTENTS

- I. Instrument Introduction 01**
 - 1.Measurement Principle 01
 - 2.Technical Specifications..... 01
 - 3.Sensor Size 02
 - 4.Features 02
 - 5.Application Areas 03
- II. Installation 03**
 - 1.Unpacking 03
 - 2.Device Connection 05
- III.Maintenance and Troubleshooting 05**
 - 1.Routine Maintenance..... 05
 - 2.Calibration 06
 - 3.Electrode Cleaning and Storage 06
 - 4. Troubleshooting 07
- IV.Reagent Formulation..... 07**
 - 1.Zero-Point Calibration Solution..... 07
- V.Communication Protocol..... 08**
 - 1.S-DO011 Modbus Communication Protocol 08
 - 2.Modbus Calibration Operation..... 09

I. Instrument Introduction

The online dissolved oxygen analyzer outputs an RS485 signal, providing stronger anti-interference capabilities for field applications.

1. Measurement Principle

Blue light emitted by an LED illuminates a fluorescent material on the inner surface of the sensor cap, exciting the material to emit red light. A photodiode detects the fluorescence intensity or the time required for the fluorescent material to return to its ground state. Higher oxygen concentrations result in weaker red light emission and shorter return times for the fluorescent material. The oxygen concentration is directly proportional to the fluorescence intensity and the time required for the fluorescent material to return to its ground state.

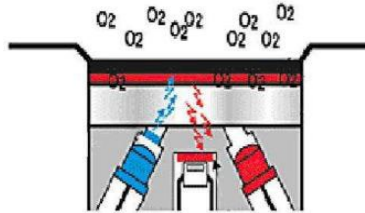

Figure 1-1 Schematic diagram of the principle of dissolved oxygen measurement by fluorescence method

2. Technical Specifications

Table 1-1 Sensor Technical Specifications

Measurement Parameters	Dissolved Oxygen, Temperature
Measurement Methods	Fluorescence quenching method
Measurement Method	Immersion measurement
Range	Dissolved Oxygen: (0-20) mg/L or (0-200)%; Temperature: (0-60)°C
Accuracy	±0.3mg/L
Repeatability	±0.3mg/L
Resolution	0.01 mg/L
Response Time	≤60s
Zero/Range Drift	±0.3mg/L
Temperature Compensation Accuracy	±0.3mg/L

Measurement Parameters	Dissolved Oxygen, Temperature
Calibration Cycle	3 months
Protection Level	IP68
Power Supply Voltage	(12/24) V DC
Power Consumption	<0.5W
Communication Methods	RS485 (Modbus RTU), maximum baud rate 115200 bps
Temperature Range	(0 ~ 60)°C
Weight/ Dimensions	0.5kg / 144mm × φ28mm
Material	Stainless steel, POM

3. Sensor Size

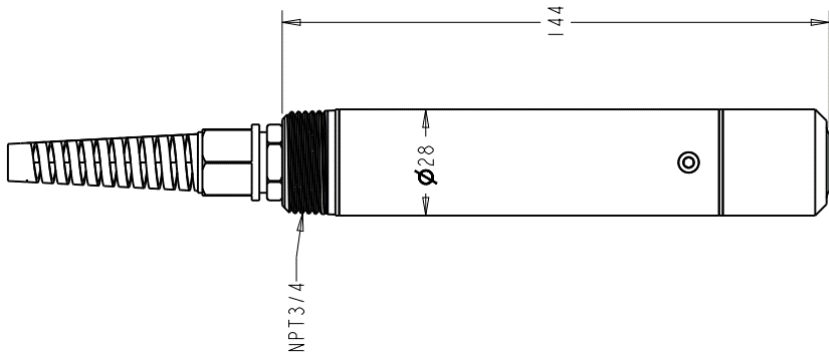

Figure 1-2 Sensor Installation Dimensions

4. Features

- Integrated design, resistant to electromagnetic interference;
- Industrial online oxygen sensing electrode, capable of stable operation for extended periods;
- Built-in temperature sensor for real-time temperature compensation;
- Supports salinity and pressure compensation;
- Stainless steel casing, IP68 waterproof rating, suitable for various working conditions;
- RS485 signal output, standard Modbus protocol, easy to integrate and network.

5. Application Areas

- Wastewater and industrial wastewater treatment processes and discharge point water quality monitoring;
- Monitoring of drinking water intake and treated water quality;
- Surface water and groundwater monitoring.

II. Installation

1. Unpacking

Upon opening the packaging, carefully inspect the instrument for any damage that may have occurred during transport. If any damage is found, record it and report the loss to the carrier, our agent, or our customer service department.

2.2 Sensor Installation

The sensor has an NPT3/4 threaded interface at the tail, making it suitable for a variety of applications, such as pipes, pools, rivers, and lakes.

Note: When installing the sensor in the designated location, be sure to remove the protective cover on the dissolved oxygen membrane cap; otherwise, the sensor will not be able to measure properly.

01. Pipeline Installation

There are two ways to install pipes: 45-degree installation and 90-degree installation, as shown in Figures 2-1 and 2-2 .

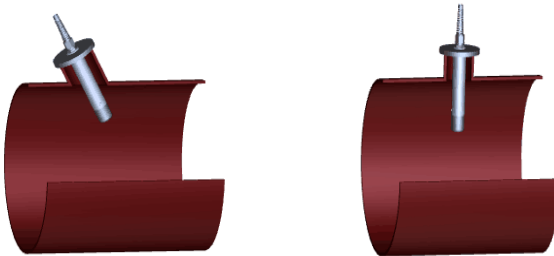

Figure 2-5 45-degree pipe installation; Figure 2-6 90-degree pipe installation

To ensure more accurate and stable measurements, the following conditions should be met when installing sensors in pipelines:

- The sensor can be fixed by thread at the tail end or by clamping it with a flange;
- Please install the electrode sensor inside a pipe with a diameter of 30 cm or more;
- When installing in a pipeline, please install the sensor in an upward-flowing pipeline, not in a downward-flowing pipeline;

- ⦿ When the sensor is installed in a horizontal pipe, ensure that the first 100mm of the sensor tip is completely submerged in water;
- ⦿ Install the sensor at least 1.5 meters downstream of the pump, valve, or pipe bend, or at a distance three times the pipe diameter.

02. Installation of open channels and water tanks

When installing open channels or water tanks, a support frame is required to fix it to the tank wall, as shown in Figure 2-3 . The support frame needs to be designed according to the specific site conditions.

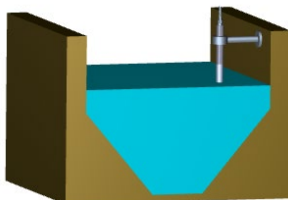

Figure 2-3 Installation of open channels and water tanks

To ensure more accurate and stable measurements, the following conditions should be met when installing sensors in rivers, open channels, and other similar locations:

- ⦿ The bottom of the sensor should be at least 10cm away from the bottom to reduce the impact of any sediment buildup on the measurement.
- ⦿ When installing the sensor, ensure the electrodes face the direction of the water flow (downstream) to reduce the risk of collision;
- ⦿ If there are large objects such as leaves in the water, a protective net should be added around the sensor.

03. Water Tank Installation

When installing the water tank, a fixing bracket is required to secure it to the tank cover, as shown in Figure 2-4 . The bracket needs to be designed according to the specific site conditions, and the opening in the water tank must ensure that the sensor can pass through the fixing hole.



Figure 2-4 Water tank installation

To ensure more accurate and stable measurements, the following conditions should be met when installing sensors in the water tank:

- The bottom of the sensor should be at least 10cm away from the bottom to reduce the impact of any sediment buildup on the measurement.

2. Device Connection

The table below is the “Sensor Wiring Definition Table”. When not powered on, connect the cable to the corresponding terminal block of the external device .

Table 2-1 Sensor Wiring Definition Table

Serial Number	Wire Color	Wiring Definition
1	Grey	RS485_A, RS485 Input Terminal_A
2	Yellow	RS485_B, RS485 Input Terminal_B
3	Red	+12V_IN, +12V power input terminal
4	Brown	GND_IN, power input ground terminal

III. Maintenance and Troubleshooting

1. Routine Maintenance

- Cable inspection: Check all connected signal power cables for breaks. If any are broken, the instrument will not function properly.
 - Visual inspection: Check the sensor housing for damage and corrosion;
 - Equipment cleaning: Clean the sensors regularly;
 - Replace the fluorescent membrane cap for dissolved oxygen using the fluorescence method: Replace the fluorescent membrane cap regularly (lifespan is about 1 year).
- ▶ **First, unscrew the old fluorescent film cap. Note: Do not let the two O-rings on the sensor body fall off .**

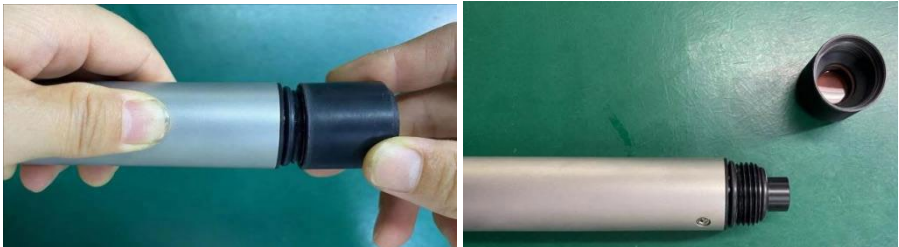

Figure 3-1 Disassembly diagram of the fluorescent membrane cap

- ▶ The second step is to screw the new fluorescent film cap onto the sensor body;



Figure 3-2 Dissolved oxygen membrane cap installation diagram

- ▶ The third step is to prepare a standard solution to test whether the dissolved oxygen sensor is working properly.

2. Calibration

During use, the fluorescent membrane cap of the dissolved oxygen sensor will be worn down, affecting the measurement results. The sensor needs to be calibrated (the cycle can vary depending on the situation; for surface water, it is generally every 6 months).

After replacing the fluorescent film cap, the sensor should be powered on and stabilized for 30 minutes before calibration.

When calibrating, please use a professional dissolved oxygen standard solution. Place the sensor in the calibration solution and ensure that the signal value is stable before starting the calibration operation.



Figure 3-3 Calibration diagram

To check if the observed signal value is correct, the electrode zero-point signal value is usually between -0.5 and 0.5.

At 25°C, the saturated oxygen signal value is usually between 7 and 12.

3. Electrode Cleaning and Storage

- Regularly check the electrodes for contaminants. If contaminants are present, rinse

with clean water; never rub the electrode caps with your hands.

4. Troubleshooting

▶ Problem 1: Communication error

Possible causes: power supply or cable connection problems, baud rate mismatch.

Troubleshooting steps: Check the power supply, check if the RS485 connection is correct, and confirm that the baud rate is correct.

▶ Question 2: Numerical instability

Possible causes: The diaphragm cap has exceeded its service life, the calibration is incorrect, or the signal is interfered with.

Troubleshooting: Ensure the fluorescent cap has not exceeded its service life. Recalibrate. If the problem persists, check for a faulty power supply and whether the shielding cable is connected correctly. If the problem still persists, please contact after-sales service.

IV. Reagent Formulation

1. Zero-Point Calibration Solution

Dissolve approximately 25 g of anhydrous Na_2SO_3 in distilled water, then add distilled water to a final volume of 500 mL. Prepare the solution before use.

2. Standard solution with a specified range

At 25 °C, air is introduced into distilled water at a flow rate of about 1 L/min until the dissolved oxygen in the water is saturated. Then, the water is left to stand for a period of time to allow the dissolved oxygen to stabilize (usually: 200 mL of water requires (5-10) min; 500 mL of water requires (10-20) min).

The above reagents should be stored in a sealed container at room temperature.

Shelf life: 6 months.

V. Communication Protocol

1. S-DO011 Modbus Communication Protocol

Register Address	Message Address	Data Types	Reading And Writing	Length	Describe
40001	0x0000	Unsigned int	R	1	Alarm code
40002	0x0001	float	R	2	Dissolved oxygen data (mg/L)
40004	0x0003	float	R	2	Dissolved oxygen data (%)
40006	0x0005	float	R	2	Temperature data
40008	0x0007	float	R	2	Dissolved oxygen signal value
40010	0x0009	float	R/W	2	Atmospheric pressure
40012	0x000B	float	R/W	2	salinity
40014	0x000C	Unsigned int	R/W	1	Average number of times (fluorescence method for dissolved oxygen)
40015	0x000D	----	-	2	NC
40017	0x0010	String	R	8	Product Name (16 Bytes)
40025	0x0018	String	R	8	Serial number (16 bytes)
40033	0x0020	String	R	1	Hardware version (1 Byte)
40034	0x0021	String	R	2	Software version (4 bytes)
40036	0x0023	Unsigned int	R/W	1	Communication address (fluorescence method: 7)
40037	0x0024	Unsigned int	R/W	1	baud rate
40038	0x0025	Unsigned int	R	1	Equipment type
40039	0x0026	----	----	11	NC
40050-51	0x0031	Float	R/W	2	When performing a calibration, enter the saturated oxygen signal value. For two-point calibration, enter: the value of the oxygen-free signal.
40052-53	0x0033	----	-	2	NC
40054-55	0x0035	Float	R/W	2	Enter "Invalid" during calibration. For two-point calibration, enter: saturated oxygen signal value.
40056	0x0037	----	-	2	NC
40058	0x0039	Unsigned int	R/W	1	Start Dissolved Oxygen Calibration Flag (0x0001: Initiate a point calibration) 0x0002: Initiating two-point calibration)
40059	0x003A	Float	R/W	2	Temperature calibration parameters
40061	0x003C	Unsigned int	R/W	1	Starter cabinet temperature calibration mark (0x0001: Start temperature calibration)
40065	0x0040	Float	R/W	2	Temperature signal value
40067	0x0042	Unsigned int	R/W	1	Temperature compensation indicator (0x0000: Automatic compensation; 0x0001: Manual compensation)
40068	0x0043	Float	R/W	2	Manual temperature compensation data

▶ Alarm code information

The alarm code consists of 16 bits, with each bit representing an alarm type. When the corresponding bit is 0, it means there is no such alarm, and when the corresponding bit is 1, it means that such an alarm has occurred.

Bit	Alarm Description	Alarm Types
Bit0	Temperature value out of range	Warning alarm
Bit1	Dissolved oxygen levels are outside the range	Warning alarm
Bit2	Fluorescence signal intensity out of range	Warning alarm
Bit8	Temperature sensor malfunction	Fault alarm
Bit9	Internal voltage reference failure	Fault alarm
Bit10	Membrane cap abnormality	Fault alarm

▶ **Baud rate**

Bit	Baud Rate
0x0000	4800 bps
0x0001	9600 bps
0x0002	19200 bps
0x0003	38400 bps
0x0004	57600 bps
0x0005	115200 bps

2. Modbus Calibration Operation

Dissolved oxygen point calibration (saturated oxygen calibration)

- ⦿ Step 1: Place the sensor in a saturated oxygen standard solution.
- ⦿ Step 2: Obtain the signal value of the electrode (40008 Float).

40008	0x0007	float	R	2	Dissolved oxygen signal value
-------	--------	-------	---	---	-------------------------------

Step 3: Write the obtained electrode signal value into the calibration value register (40050 Float).

40050	0x0031	Float	R/W	2	Enter the saturated oxygen signal value.
-------	--------	-------	-----	---	--

Step 4: Start a point calibration and rewrite register 40058 to 0x0001.

40058	0x0039	Unsigned int	R/W	1	Write it as 0x0001 to initiate a point calibration.
-------	--------	--------------	-----	---	---

Dissolved oxygen two-point calibration

- Step 1: Place the sensor in an oxygen-free standard solution.
- Step 2: Obtain the signal value of the electrode (40008 Float).

40008	0x0007	float	R	2	Dissolved oxygen signal value
-------	--------	-------	---	---	-------------------------------

Step 3: Write the obtained electrode signal value into the calibration value register

(40050 Float).

40050	0x0031	Float	R/W	2	Enter the anaerobic signal value
-------	--------	-------	-----	---	----------------------------------

Step 4: Place the sensor in a saturated oxygen standard solution.

Step 5: Obtain the signal value of the electrode (40008 Float).

40008	0x0007	float	R	2	Dissolved oxygen signal value
-------	--------	-------	---	---	-------------------------------

Step 6: Write the obtained electrode signal value into the calibration value register (40050 Float).

40054	0x0035	Float	R/W	2	Enter the saturated oxygen signal value.
-------	--------	-------	-----	---	--

Step 7: Start two-point calibration and rewrite register 40058 to 0x0002.

40058	0x0039	Unsigned int	R/W	1	Write it as 0x0002 to start two-point calibration.
-------	--------	--------------	-----	---	--

Temperature one-point calibration

Step 1: Write the accurate temperature of the current solution into the temperature calibration parameter register (40059 Float).

40059	0x003A	Float	R/W	2	Temperature calibration parameters
-------	--------	-------	-----	---	------------------------------------

Step 2: Start temperature calibration and rewrite register 40061 to 0x0001.

40061	0x003C	Unsigned int	R/W	1	Write it as 0x0001 to start temperature calibration.
-------	--------	--------------	-----	---	--



Linksens

LINKSENS LIMITED

Tel: 085270107898

Website: www.linksens-hk.com

Email : sales@linksens-hk.com

Address: Room 22, 15/F, Beverley Commercial Centre, 87-105
Cnatham Road South, Tsim Sha Tsui, Hong Kong